

Producer of Stainless Steel
Construction Materials

ALLOY
ALLOY CORPORATION

Alloy Stainless Steel Welded Shapes

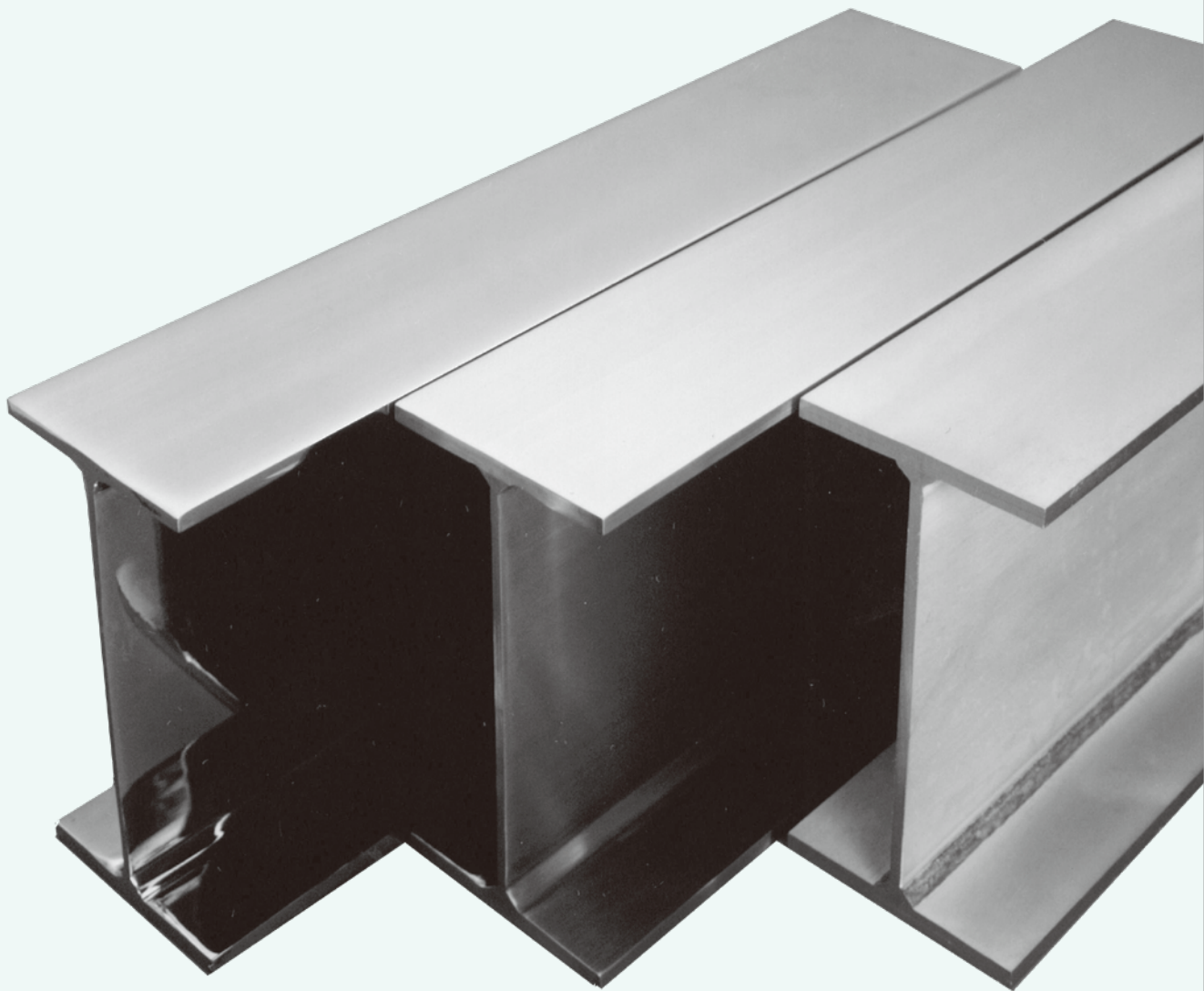

Alloy Stainless Steel Welded Shapes

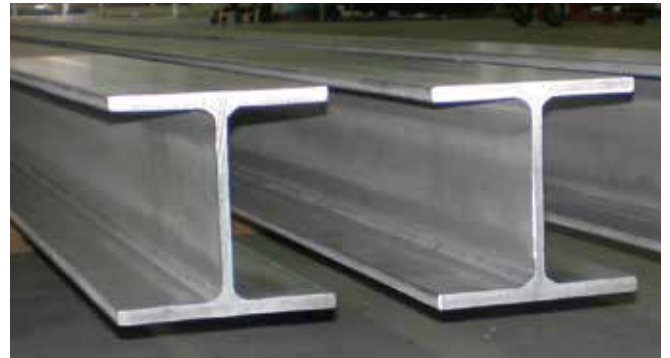
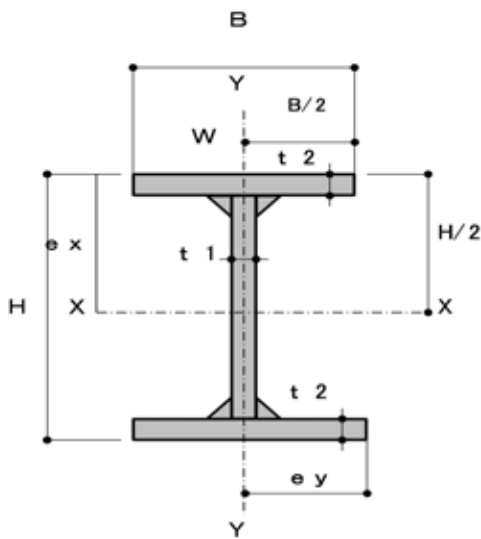

▲Standard cross section

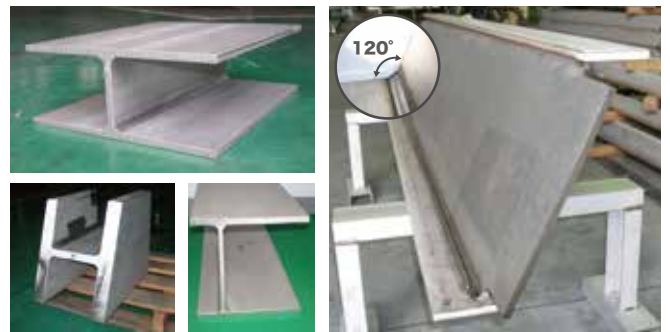

▲Manufacturing of special shapes

Manufacturable Range

	Width		Thickness	
	Height (H)	75-1100	web(t1)	5-25
Sides (B)	50-400	flange(t2)	5-30	

*When flange sheet thickness (t2) is 12mm or greater, from height (H) 200 and Side (B) 175 and greater can be manufactured.

*As steel sheets are manufactured after being cut, Sides (B) and Height (H) can be freely manufactured in 1-mm increments.

*Sizes outside the manufacturable range and product fabrication can also be considered. Please inquire with a sales representative.

(Example)

Manufacturing of $H < B$ cross section

Manufacturing of welded channel steel, welded T-beam steel, and manufacturing of other welded shaped steel with special cross sections

Handling of groove fabrication, perforation, scrap processing and other processes

List of Standard Sizes and Cross-Sectional Performance

Material Quality: SUS304 (JIS G4304)

Standard Cross-sectional Dimensions (mm)				mass per meter (kg/m)	Item with standard length (6m) Weight (kg)	Area of section (cm ²)	Moment of Inertia of area (cm ⁴)		Radius of gyration (cm)		section modulus (cm ³)	
Height H	Width B	W-thickness t1	F-thickness t2				a	Ix	Iy	ix	iy	Zx
75	X 75	X 5	/ 8	11.9	71.1	14.950	143.9	56.3	3.10	1.94	38.36	15.02
100	X 100	X 6	/ 8	16.7	100.1	21.040	369.0	133.5	4.19	2.52	73.81	26.70
125	X 125	X 7	/ 9	23.8	142.7	29.990	829.9	293.3	5.26	3.13	132.78	46.92
148	X 100	X 6	/ 9	20.5	122.8	25.800	980.5	150.2	6.16	2.41	132.50	30.05
150	X 150	X 8	/ 10	32.0	192.8	40.400	1,619.0	563.1	6.33	3.73	215.86	75.07
200	X 100	X 6	/ 8	21.4	128.7	27.040	1,786.9	133.7	8.13	2.22	178.69	26.73
200	X 200	X 8	/ 12	49.2	295.4	62.080	4,610.5	1,600.8	8.62	5.08	461.05	160.08
250	X 125	X 6	/ 9	28.9	173.3	36.420	3,892.9	293.4	10.34	2.84	311.43	46.94
250	X 250	X 9	/ 14	71.4	428.1	89.980	10,578.8	3,647.2	10.84	6.37	846.30	291.77
300	X 300	X 10	/ 16	97.4	584.3	122.800	20,982.0	7,202.2	13.07	7.66	1398.80	480.15

Manufactured Steel Types

*Please inquire about steel types other than SUS304, SUS316 and SUS316 L.

Austenitic Stainless Steel : JIS G4304 / SUS304 · SUS316 · SUS316L · SUS309S · SUS310S

Duplex Stainless Steel : JIS G4304 / SUS329J3L · SUS329J4L · SUS821L1 · SUS323L

: S32304 · S31803 · S32750

Aluminum : JIS H4000 / A5083

Titanium : JIS H4600 / TP340H

Product Specifications

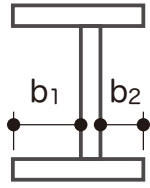
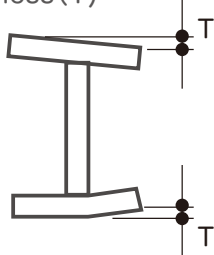
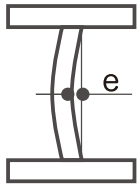
Dimensional Allowances		(mm)
Category	Allowance	
Height(H) $H \leq 300$ $300 < H \leq 600$ $600 < H$	± 2.0 ± 3.0 ± 4.0	
Sides(B)	± 2.0	
Center Deviation(C) 	± 2.0 $C = \frac{(b_1 - b_2)}{2}$	
Squareness(T) 	1.2% of sides (B) or less However, minimum allowance is 2.0	
Length	-0, +40	
Bending	0.2% of length or less	
Web Bending(e) 	H/150 or less However, minimum allowance is 5.0	
Not applied for $t \leq 6$		
Thickness(t_1, t_2)	JIS allowance for steel sheets (JISG4304)	

Tensile Testing

Test Specimen: SUS304 (JIS G4304) BH100x100x6/8



▲ Welded spot penetration state



▲ After tensile testing
 (*fracture of base material part)

Through the manufacturing of welded structures made from stainless steel, aluminum, titanium and other materials,
Alloy supports the world's "tomorrow."

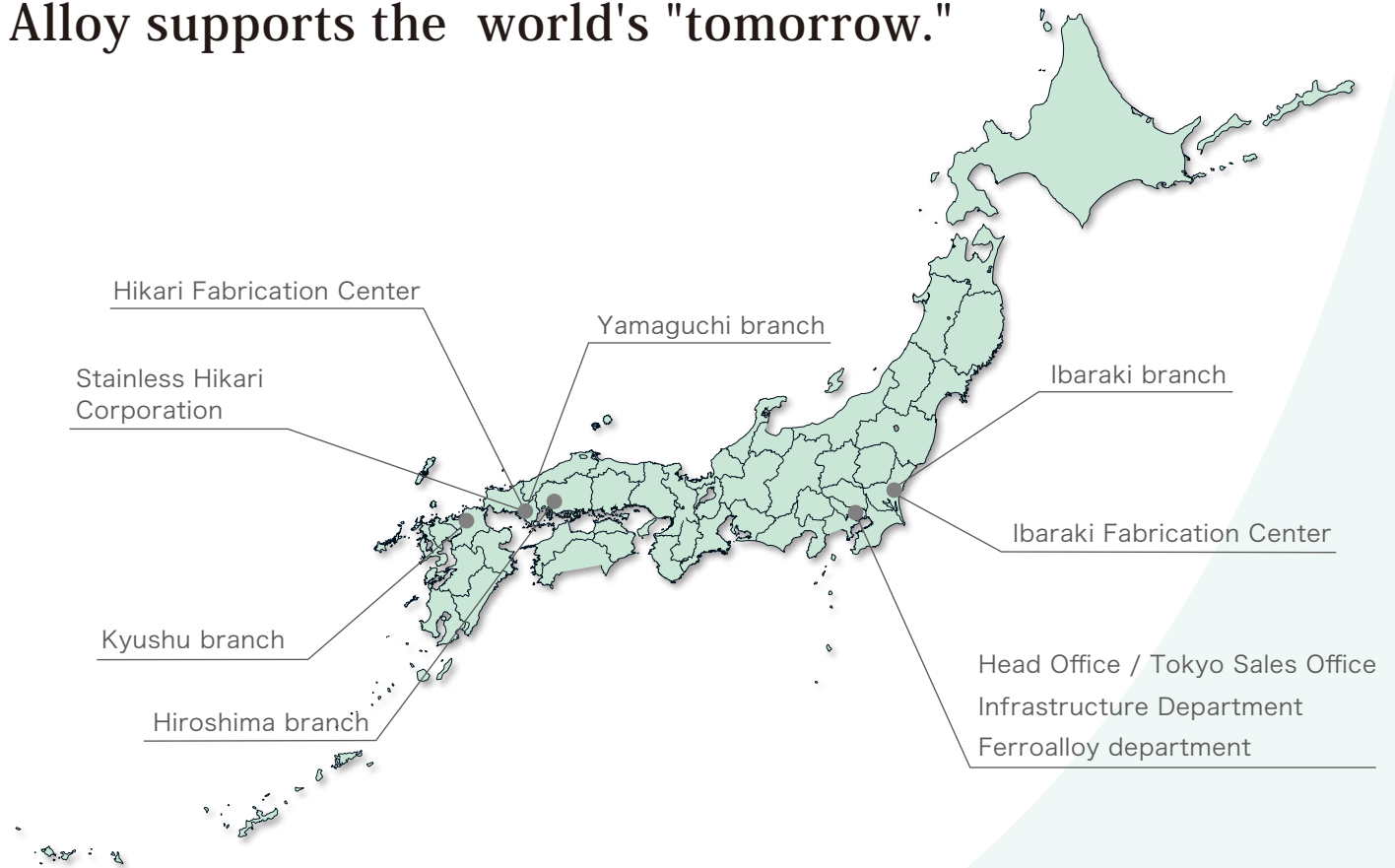

Head Office	Colver-shibakoen3F, 1-3-12, Shibakoen, Minato-ku, Tokyo, 105-0011, Japan Tel: +81-3-3432-3193 / Fax: +81-3-3432-3196
Factory	Hikari Fabrication Center Suo Industrial Park, 1100-3, Nijikawa Kozuo, Hikari-shi, Yamaguchi Ken, 743-0061 Japan Tel: +81-833-77-3937 Fax: +81-833-77-1918
	Ibaraki Fabrication Center 989-1, Mukoyama, Naka-shi, Ibaraki Ken, 311-0102, Japan Tel: +81-29-295-3381 Fax: +81-29-295-0567
Branch	Tokyo branch Colver-shibakoen3F, 1-3-12, Shibakoen, Minato-ku, Tokyo, 105-0011, Japan Tel: +81-3-3432-3191 / Fax: +81-3-3438-1277
	Ibaraki branch 989-1, Mukoyama, Naka Shi, Ibaraki Ken, 311-0102, Japan Tel: +81-29-295-3381 / Fax: +81-29-295-0567
	Yamaguchi branch 1100-3, Nijikawa Kozuo, Hikari Shi, Yamaguchi Ken, 743-0061, Japan (Suo Industrial Park) Tel: +81-833-77-3927 / Fax: +81-833-77-1917
	Hiroshima branch Hirosimasyoukoukaigisyo Bld.8F, 5-44, Motomachi, Hiroshima Shi Naka Ku, Hiroshima Ken, 730-0011, Japan Tel: +81-82-502-6800 / Fax: +81-82-502-6801
	Kyushu branch 302, Abandanto90, 3-11-14, Hakataeki Higashi, Fukuoka Shi Hakata Ku, Fukuoka Ken, 812-0013, Japan Tel: +81-92-476-5821 / Fax: +81-92-476-5826
	Infrastructure Department Colver-shibakoen3F, 1-3-12, Shibakoen, Minato-ku, Tokyo, 105-0011, Japan Tel: +81-3-3432-3195 / Fax: +81-3-3432-3196
	Ferroalloy department Colver-shibakoen3F, 1-3-12, Shibakoen, Minato-ku, Tokyo, 105-0011, Japan Tel: +81-3-3432-3193 / Fax: +81-3-3432-3196
Group company	Stainless Hikari Corporation 501, Ogo, Kumage Gun Tabuse Cho, Yamaguchi Ken, 742-1513, Japan Tel: +81-820-52-3210 / Fax: +81-820-52-3190